

SYRINGE HEATER THERMO KINETIC HEAT CLAMPING

Model: PSHEATER-KIT-1LG
PSHEATER-KIT-5SP

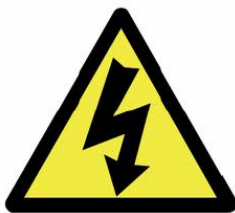

CAUTION
RISK OF
ELECTRIC SHOCK

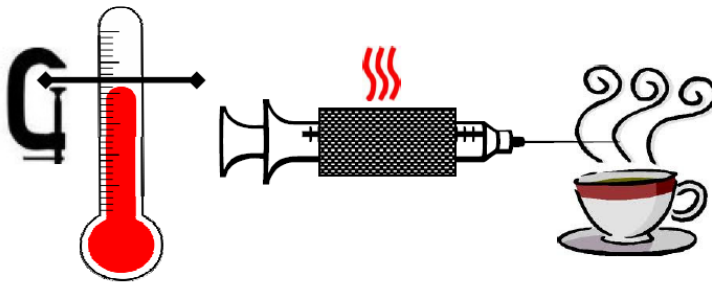

CAUTION:
SURFACE OF HEATING
PADS WILL GET VERY
HOT

WARNING
NOT FOR CLINICAL
USE ON HUMANS

1. General Information

Thank you for purchasing the Syringe Heater Kit. Please familiarize yourself with the Syringe Heater's operation by reading this user's manual. For future reference, record the serial number, located on the bottom identification label, and the date of purchase.













ProSense B.V., can be contacted at:

De Kreek 12
4906 BB OOSTERHOUT
THE NETHERLANDS
Phone: +31 (0)162 471485
Fax: +31 (0)162 471486
info@prosense.net
www.prosense.net

This Operating Manual, and the Syringe Heater's hardware, electronics, and firmware are copyrighted.

Copyright 2012, all rights reserved.

1.1 Warnings and Cautions

-  Read the user's manual
-  Risk of electrical shock. Do not cut heating pads.
-  Surface of heating pads can get very hot
-  No user serviceable parts are inside.
-  Disconnect power from the heater when connecting or disconnecting cables.
-  Do not immerse the heater control unit or pads in liquid
-  Install on a stable surface.
-  The heater can automatically start when the heater is operating or when attached to an external control device.
-  Prevent liquids from entering openings.
-  Only connect to a power source as specified on the power supply label.
-  Do not push objects of any kind into openings, except for appropriate cables and connectors.
-  If the heater becomes damaged, do not use unless certified safe by a qualified technician. Damage includes, but is not excluded to, frayed cords and deterioration in performance.
-  Discharge static from control cables before connecting by touching the cable to ground

1.2 Disclaimer

ProSense B.V. makes no representations or warranties, expressed, statutory or implied, regarding the fitness or merchantability of this product for any particular purpose. Further, ProSense B.V. is not liable for any damages, including but not limited to, lost profits, lost savings, or other incidental or consequential damages arising from ownership or use of this product, or for any delay in the performance of its obligations under the warranty due to causes beyond its control. ProSense B.V. also reserves the right to make any improvements or modifications to the product described in this manual at any time, without notice of these changes.

ProSense B.V. products are not designed, intended, or authorized for use in applications or as system components intended to support or sustain human life, as a clinical medical device for humans, or for any application in which the failure of the product could create a situation where personal injury or death may occur.

All brand and product names used in this manual are the trademarks of their respective owners.

1.3 Warranty

ProSense B.V. warrants this product and accessories for a period of two year, parts and labor, from the date of purchase. The repaired unit will be covered for the period of the remainder of the original warranty or 90 days, whichever is greater.

A return authorization number must be obtained from ProSense B.V. before returning a unit for repair. Warranty covered repairs will not be performed without a return authorization number. At the option of ProSense B.V. a defective unit will be either repaired or replaced.

This warranty does not cover damage by any cause including, but not limited to, any malfunction, defect or failure caused by or resulting from unauthorized service or parts, improper maintenance, operation contrary to furnished instructions, shipping or transit accidents, modifications or repair by the user, harsh environments, misuse, neglect, abuse, accident, incorrect line voltage, fire, flood, other natural disasters, or normal wear and tear. Changes or modifications not approved by ProSense B.V. could void the warranty.

The foregoing is in lieu of all other expressed warranties and ProSense B.V. does not assume or authorize any party to assume for it any other obligation or liability.

1.4 Packing List

Included with the Syringe Heater are the following items:

- Primary heating pad with 2 releasable plastic ties
- Basic Operating Manual





2. Overview

The syringe heater controls the power to a heating pad with a temperature sensor. It is controlled from a microcontroller based system which monitors and regulates the temperature on the heating pad.

Features:

- User adjustable Thermo-Kinetic Heat Clamping for precision regulation of Set Point temperature.
- Maximum temperature of 185 C
- Non-volatile memory of all operating parameters.
- RS-232 bi-directional control from a computer with built- in RS-232 network driver. RS-232 network supports up to 100 heaters, pumps and other devices from a single computer port.
- Power Failure Mode: Restarts the heater Active Mode after a power interruption.
- Selectable Temperature units of C or F (Celsius or Fahrenheit)

3. Setup

- Attach the primary heating pad to the larger connector (8 pin) on the end of the heater control box.
- Wrap the primary heating pad around the syringe body. Temperature will be measured near the point where the wires are attached to the heating pad. Secure the heating pad to the syringe with the 2 releasable plastic ties.
- Plug in the heater.
- Use the Up  and Down  arrow buttons to adjust the temperature Set Point.
- To start heating the pad, simultaneously press the 2 ACTIVE buttons,  and . The ACTIVE LED will be lit. The heater will begin to regulate the temperature on the pad.
- Press the  button to stop heat regulation and exit Active Mode.
- The temperature Set Point can be adjusted while in Active Mode

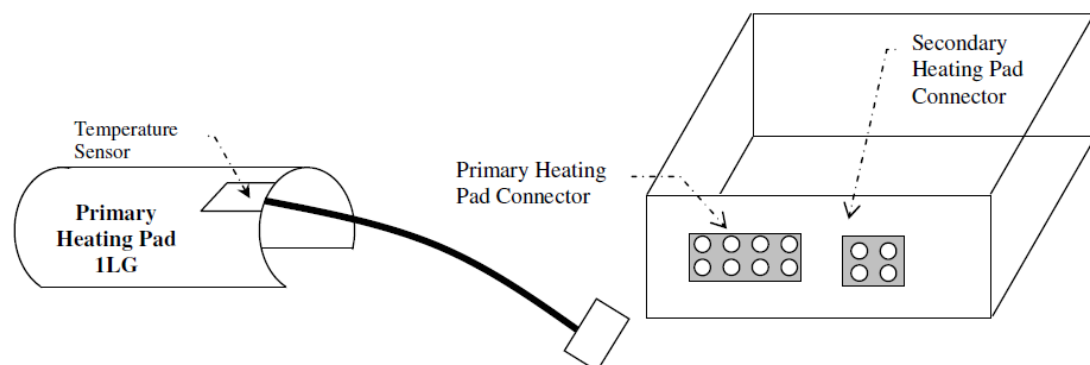

4. User Interface

The controller will display, as the default display, the current temperature of the primary heating pad, in the currently selected unit, C or F.

LEDs indicate the status of the heater.

ACTIVE	Temperature Set Point is actively being maintained
OUT	Heating pads are being powered. Flashing indicates on/off power duty cycle to slow down heating when near the Set Point
ALARM	Heating pad temperature is greater than 20 degrees C above the Set Point

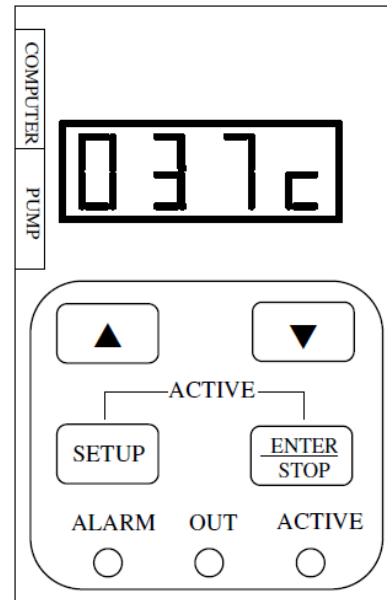

Keypad

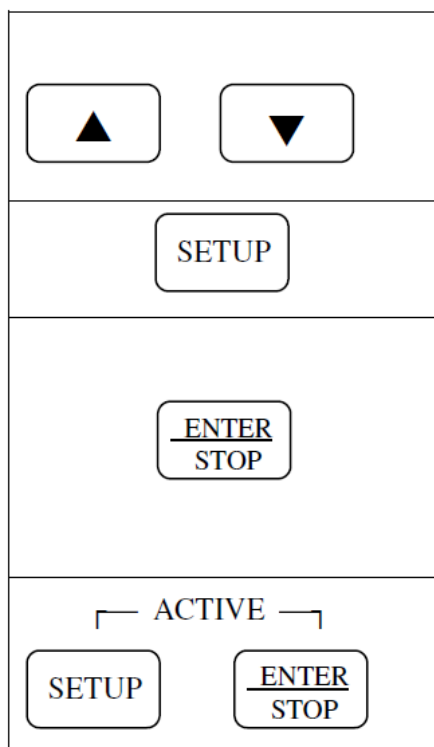

Up/Down Arrow Buttons

Increases or decreases settings. By default, will change the temperature Set Point
Settings with decimal points: Press both buttons simultaneously to shift the decimal point.

SETUP Button

Displays the setup menu. Each press will display the next menu selection.

ENTER / STOP Button

When displaying the setup menu or changing a value, will select the entry or save the new value. The display will blink when the new value is saved in non-volatile memory.
Otherwise, will stop the heater. The Active LED will turn off. Temperature will no longer be maintained.

Active Mode Buttons

Simultaneously press the SETUP and ENTER/STOP buttons. The Active LED will turn on and the heating pads will start heating until the temperature reaches the Set Point.

5. Setup Settings









Press the SETUP button  to display the setup menu. Each press of the Setup button will display the next menu entry. All settings are saved in non-volatile memory. Pressing an Up or Down arrow button will immediately select Temperature Clamping Set Point and will increment or decrement the setting.

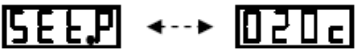
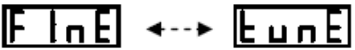

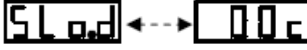
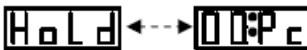
Press ENTER  to select a menu entry or accept and enter a setting, exiting Setup Configuration.

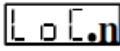
A value being changed will be automatically entered after a few seconds time out period. The display will blink to indicate the value has been entered and saved in non-volatile memory.

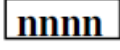
Press an Up or Down arrow button  or  to change a displayed setting.

The setup menu is as follows:  Indicates that the display alternates between 2 displays.

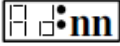
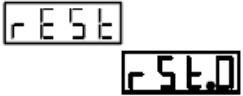
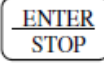
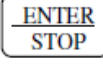
Temperature Clamp Set Point 	When active, the heater will heat the pads until the set point is reached on the primary pad. Use the Fine Tune settings to control the regulation of the temperature clamping. Alarm Set Point will be 20 degrees C (36 F) above the Set Point.
Fine Tune Temperature Set Point 	Fine Tunes thermo-kinetic settings to improve regulation of temperature Set Point clamping. Press  to display the Fine Tune settings sub-menu.
Slow Down Temperature Delta 	Degrees below Set Point to begin heating slow down. Heating duty cycle will be reduced based on degrees below temperature set point and rate of temperature change. Set to 0 to disable. Default = 10.
Set Point heat clamping duty cycle base percentage (Pc). 	Hold duty cycle percentage is the base heat duty cycle percentage to trickle charge the heaters to clamp the temperature setting. Actual percentage will be dynamically adjusted up or down according to temperature feedback. Set to 0 to disable. Default = 10.
	This setting will not appear in Active Mode. C is default setting Set temperature units: C or F (Celsius or Farenheit). When the units are changed, all settings will change units without being converted.
	Enable Lock Out Mode. Set to 1 to enable. 0 is default setting. Press  when enabled to set Lock Out code.
	Lock Out code: use arrow keys to set blinking digit. Press  or  to move to next digit.

	<p>Power failure mode. Set to 1 to enable. 0 is default setting.</p> <p>When Power Failure Mode is enabled, if the heater loses power while in Active Mode, the heater will power up in Active Mode when power is restored. Alarm mode will override Active Mode.</p>
	<p>RS-232 communications network address. 0 is default setting.</p> <p>Sets the RS-232 network address for use with a network of heaters and pumps connected to a computer. 00 is the default address.</p>
	<p>This setting will not appear in Active Mode</p> <p>Reset all settings. First press  to select.</p> <p>Then set to '1'. Press  again to reset all settings to default settings. '0' will exit reset without making any changes.</p>
	<p>Displays the firmware version.</p>

6. Operation

The heater constantly monitors and displays the temperature measured on the primary heating pad.

In Active Mode, the heater will apply power to the heating pads, as indicated by the OUT LED, until the Set Point temperature is measured on the heating pad. In Thermo-Kinetic mode, the OUT LED will pulse on and off, indicating a partial heating duty cycle.

6.1 Thermo Kinetic Mode

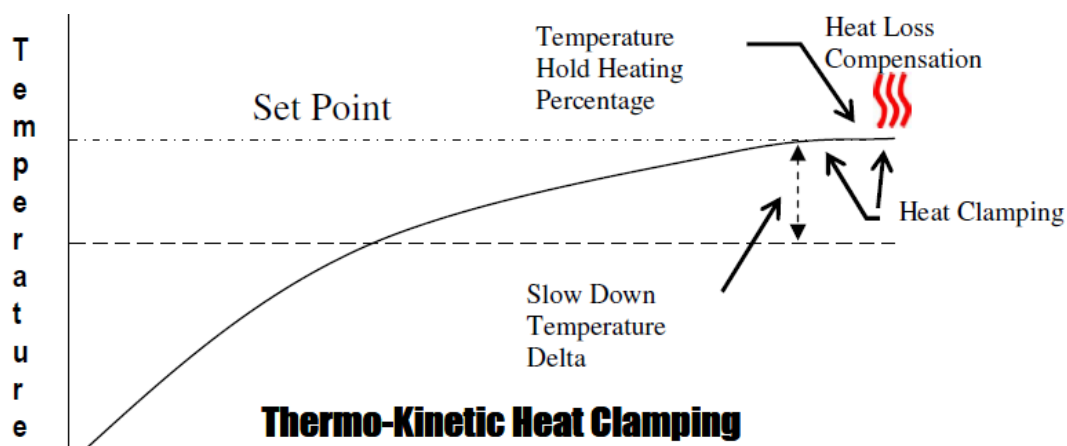

Setup settings "Slow Down Temperature Delta" and "Hold Percentage" configure Thermo-Kinetic Mode. The default settings are 10 degrees C Slow Down Delta and 10% power Hold Heating percentage.

When Thermo-Kinetic Mode is off (settings set to 0), power to the heating pads will remain on until the Set Point is reached. Then turn on again when the temperature reduces to below the Set Point. This will generally cause large temperature swings. When power is turned off to the heating pads, the temperature will continue to rise for several seconds.

Thermo-Kinetic Mode reduces the average power to the heating pads by dynamically reacting to changes in the temperature measurement and rate of change. Then, when the Set Point is reached, the average power applied to the heating pads will be reduced to a level that dynamically compensates for heat loss, clamping the temperature at the Set Point. The average power is set by controlling the on/off power duty cycle of the heating pads, as indicated by the pulse rate of the OUT LED.

Slow Down Temperature Delta **5 L o. d** ←--→ **00 c**

Set to the number of degrees below the Set Point to begin reducing the average power to the heating pads. Increasing this number will minimize over shooting the Set Point. The larger the number, the longer it will take to reach the Set Point. A good starting value is 10 degrees.

The average power will be linearly reduced in proportion to the temperature delta below the Set Point. Then the power level will be adjusted based on the temperature change over time (temperature derivative).

Hold Percentage **H o L d** ←--→ **00: P c**

The Hold Percentage provides just enough power to the heating pads to compensate for heat loss, clamping the temperature at the set point. The temperature hold heating percentage is used when the temperature is within +/- 1 degree of the Set Point temperature.

The actual Hold Percentage is dynamically adjusted according to the measured temperature. When the temperature settles below the Set Point, the adjusted percentage is incremented. When the temperature settles above the Set Point, the adjusted percentage is decremented. These small changes in power will slowly nudge the temperature towards the Set Point, while minimizing over/under shooting.

The Hold Percentage setting remains unaffected by the adjusted setting. The adjusted setting remains in affect until the heater control box is powered off. A good starting value is 10 Percent.

6.2 Alarm Mode

When the measured temperature reaches 20 C (36 F) above the Set Point, Alarm Mode is set. The heater exits Active Mode, turning the “Active” LED off, the red “Alarm” LED on, and the alarm message **AL:HE** will flash.

The message can be cleared by pressing any key after Alarm Mode is cleared. Alarm Mode is cleared, turning the “Alarm” LED off, when the measured temperature reduces to the set point, or the set point is raised.



6.3 Error Messages



Indicates a system fault, where 'n' is the fault code

1	Heater pad sensor differential
2	Control box internal temperature
3	Heater pad sensor minimum temperature

6.4 Calibration

Heating pad calibration is performed through the RS-232 computer interface using the CAL command.

Calibration is performed by measuring the primary heating pad temperature at 2 temperatures: One at room temperature, and one at a high set point of at least 25 C above room temperature. Measurements are in Celsius units.

Notes on measuring the heating pad temperature:

Measure the temperature on the inner part of the primary heating pad curve, under the temperature sensor. Only the primary heating pad, with a sensor, can be calibrated.

- 1) Power on the syringe heater.
 - Attach the computer cable (CBL-PC-PUMP-7) and start the terminal emulator PUMPTERM.EXE.
 - Verify communications is established with the heater by pressing the ENTER key on the PC. A response from the heater will indicate communications is established.

- 2) Measure the low point temperature.
 - Allow the temperature on the heating pad to reach room temperature for at least 1 minute.
 - Measure the temperature on the heating pad.
 - Very quickly, after reading the temperature, enter the low point temperature as a 1 to 3 digit Celsius number (spaces are optional) with the following command:
CAL L nnn

- 3) Measure the high point temperature.
 - On the syringe heater, or from the PC, enter a temperature set point at least 25 degrees higher than the room temperature. To set from the PC, use the SET command. For example to set a 75 degree set point (assuming C units set), enter:
SET 75
 - Start the syringe heater by pressing the Active buttons, or from the PC, use the RUN command.
 - Wait for the heating pad to reach the set point. Then wait 1 minute for the temperature to settle and dissipate throughout the heating pad.
 - Measure the temperature on the heating pad.

- Very quickly, after reading the temperature, enter the high point temperature as a 1 to 3 digit Celsius number (spaces are optional) with the following command :
CAL H nnn
- 4) Finalize the heating pad calibration.
- The calibration entry process can be repeated before the process is finalized, or the entries can be ignored if the process is not finalized. Turning off power will discard the entries.
 - To finalize the calibration, enter the command:
CAL
 - If the calibration data was valid, the heater will respond with:
OK
 - If there was an error in the calibration, the heater will respond with:
?NA
 - After calibration, the heating pad number will be set to 0. Selecting pad number 1, will change the calibration back to the factory defaults:
PAD 1

6.5 Lock Out Mode

When enabled, Lock Out mode will lock out the keypad until the user defined lock out code is entered.

If any key is pressed while locked out, the display will show:

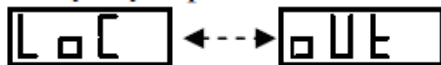

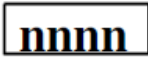
Pressing either arrow key will enter Lock Out code entry mode: .
Any other button will return to the previous display.



Use the arrow buttons to set the blinking digit. Press the Setup or Enter buttons to move to the next digit.



If the code entered is wrong, the display will show: .
Press any button to clear.

If the code is correct, the keypad will be unlocked, but Lock Out setting will remain enabled. The next time power is turned on, the keypad will be locked out. Use Setup mode to disable Lock Out mode.



RS-232 communications is not affected by Lock Out Mode. Also, Lock Out can be set remotely.

6.5.1 Setup

Use the  button to select Lock Out Mode: 

where 'n' indicates the current setting:
'1' enabled and '0' disabled. Use the up  and down  buttons to select, then press 

If enabled, then the current Lock Out code is displayed and can be changed.

To change the code, use the up  and down  buttons to change the blinking digit.

Press  or  to move to next digit.

After the last digit the new code is entered.
The keypad will be immediately locked out upon entering the Lock Out code.

6.5.2 Default Code Bypass

If the lock out code is forgotten, the default code can be entered: While turning on power to the unit, press and hold the Setup key. Lock Out code entry mode will be displayed. To unlock the keypad, enter the code: 1392.

7. RS-232 Communications

The syringe heater can communicate with any computer or device with an RS-232 communications port or converter.

7.1 Connection and Networking

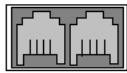

On the side of the heater are 2 square RJ-11 (“phone jack” style) sockets. Connect the RS-232 cable (CBL-PC-PUMP-7) into the socket labeled “Computer”. Connect the other end to the serial port on the computer, or other control device.

If the heater is part of a RS-232 network, connect a RS-232 network cable (CBL-NET-7) between the socket labeled “Pump” on the heater and the socket labeled “Computer” on the next device in the network. Repeat for each device in the network, connecting the “To Network” or “Pump” socket of one device to the “Computer” socket on the next device in the network. Up to 100 devices can be networked together with a computer. When communicating with a device in a multi-device network, each preceding device in the network must be powered on.

Each device in the network needs a unique network address to identify the device to the computer. Network addresses are from 00 to 99. If the network consists of only 1 device, set the device’s address to 0. Also, each device needs to be set to the same baud rate as the computer. Use the ‘Setup’ function on the keypad to set the network address. See section 5, “Setup Settings”. The ‘*ADR’ command can also be used to set the network address.

The supported baud rate is 19200

7.2 RS-232 Protocol

When the device is used in a multi-device network configuration, precede each command with a device address. Devices will ignore all commands that do not have their defined network address. If the network address is not specified in the command, the address will default to 0.

After a command is sent to the device, the device will not accept any further communications until the current command has been processed. Completion of the command processing is indicated when the first byte of the response packet is transmitted. While the user is changing data or configurations from the keypad, command processing is delayed.

Communications to and from the device uses the following data frame:

Supported RS-232 Data Frame

Baud rate: 19,200
 Frame: 10 bit data frame (8N1):
 Start bit: 1
 Data bits: 8
 Stop bits: 1
 Parity: None

Every command received by a device in the network is acknowledged by the device with a response packet that includes a status character indicating the current operational state of the device.

7.2.1 RS-232 General Syntax Legend

The following syntax expansion legend is common to all syntax expansions: Except where indicated, all command and response characters are ASCII data.

<float> => <f> [<float>]	Floating point number. Maximum of 4 digits plus 1 decimal point. Maximum of 3 digits to the right of the decimal point.
<on-off> =>	1 On, enabled 0 Off, disabled
<count data> => <n> [<n>]	Valid values: 1 to 99
<number data> => <n> [<n>]	Valid values: 0 to 99
<text> => "any printable character" [<text>]	
<f> => { <n> . }	Floating point digits
<n> => { 0 1 2 3 4 5 6 7 8 9 }	Digits
<byte> => "one byte of any data"	
()	One byte of data expressed as (0xhh), where 'hh' is the data in hexadecimal.

=>	Is defined by. Syntax expands to next level of expansion.
< >	Non-terminal syntax expansion
[]	Optional syntax
{ }	Required syntax
	Or. Choose one of the syntax options.
λ	None. Syntax expands to nothing (lambda production).
" "	Description of syntax expansion

7.2.2 RS-232 Protocol: Basic Mode

Command syntax (to device):

<basic command protocol> => <command data> <CR>

Response syntax (from device):

<basic response protocol> => <STX> <response data> <ETX>

In the “Basic” communications mode, a master-slave protocol is used, whereby the device will only transmit in response to a received command.

When the device receives the <basic command protocol>, <command data> will automatically be stripped of all space and control characters, and all text will be converted to upper case. This simplifies communications with the device when commands are being manually typed in from a generic terminal emulator.

7.2.3 RS-232 Protocol: Basic Mode Common Syntax

<transmitted data> => { <command data> | <response data> }

<command data> => [<address> | *] [<command>]

<response data> => <address> <status> [<data>]

<status> => { <prompt> | <alarm> }

To device
From device
Operational state
of device

<prompt> =>

S	Heater Stopped
H	Heater Active
A	Heater Alarm

<alarm> => A ? <alarm type> Alarm

<alarm type> =>

R	Heater power was reset (power was interrupted)
E	Error
O	Out of range
H	High temperature alarm
F	Sensor Fault

<address> => <n> [<n>] *	Device network address, 0 to 99 System command (overrides network address)
<data> => <text>	Response to command
<CR> => (0x0D)	Carriage return
<STX> => (0x02)	Start of packet transmission indicator
<ETX> => (0x03)	End of packet transmission indicator
<length> => <byte>	Number of bytes remaining in packet, including this byte

7.3 Command Errors and Alarms

If a command received by the device is not recognized or the data is invalid, an error message will be in the <data> field of the response packet following the <prompt> field. The following are the error responses:

<command error> => ? <error>

<error> =>

λ	Command is not recognized ('?' only)
NA	Command is not currently applicable
OOR	Command data is out of range
COM	Invalid communications packet received
IGN	Command ignored due to a simultaneous new Phase start

When an alarm occurs, the alarm must be acknowledged before any data is changed or the device is started. Alarms are acknowledged by the user clearing the alarm message on the keypad, or the alarm status being sent in response to any valid RS-232 command.

7.4 RS-232 Command Set

Data changes made from RS-232 will not be stored in non-volatile memory until a Save command is executed: SAV

A packet without a command is interpreted as a status query. The addressed device responds with a status only response packet.

Except where noted, a setting command without its parameter queries the command setting. The response packet data will include the requested data. In general, the query response data will be in the same format as the parameter for setting the command. For example, the query temperature setpoint command 'SET' will respond with '<nnn>' as the response '<data>'.

Otherwise, the command is a set command. If the data was set, a status only response packet will be sent. If the data was not set, the response packet will include an error (<command error>) message indicating why the data was not set.

All commands are upper case. Spaces are optional. Lower case letters are converted to uppercase when received.

7.5 RS-232 Commands

<command> =>

HEATING COMMANDS

START ACTIVE HEATING MODE

RUN Enter active mode, maintaining heating temperature.

STOP ACTIVE HEATING MODE

STP Exit active mode. Stops heating the heating pads.

TEMPERATURE QUERY

TMP Query primary heating pad temperature in currently set units.
Query response: <nnn>

HEATING SET POINT

SET [<nnn>] Set/Query Heating set point in currently set units.
Query response: <nnn>

TEMPERATURE FINE TUNE SLOW DOWN DELTA

FTS [<nnn>] Set/Query Fine Tune Slow down degree setting.
Query response: <nnn>

TEMPERATURE FINE TUNE HOLD PERCENTAGE

FTH [<nnn>] Set/Query Fine Tune temperature hold percentage.
Query response: {nnn}

CALIBRATION

CAL [< L | H > [<nnn>]] Heating pad calibration. See calibration section for details.

HEATING PAD SELECTION

PAD [n] Heating pad calibration setting. 1 – Default. 0 – Calibrated.
Query response: <n>

TEMPERATURE UNITS

UNT [C | F] Set/Query temperature units
Query response: {C | F}



GENERAL SETUP COMMANDS
SAVE NEW SETTINGS

SAV Save all new settings in non-volatile memory

POWER FAILURE MODE

PF [0 | 1] Set/Query Power Failure mode
Query response: {0 | 1}

LOCK OUT MODE

LOC [< 0 | 1 [<nnnn>] > Set/Query Lock Out mode
Query response: {0 | 1 <nnnn>}

NETWORK ADDRESS

ADR [<nn>] Set/Query RS-232 network address
Query response: <nn>

FIRMWARE VERSION

VER Query firmware version.
Query response: NE800V<n>.<nn>

SYSTEM RESET

RESET Reset all parameters to factory defaults

8. Accessories

8.1 Additional Heating Pads

Only the primary heating pad has a temperature sensor. Additional heating pads do not have temperature sensors. The heating pads will heat when the primary heating pad heats. Each heating pad must be the same type and size as the primary heating pad. The following are part numbers for ordering additional heating pads:

Type	Base Model	Replacement Primary Pad	Second Heating Pad	Third and Additional Heating Pads
Large	SYRINGE-HEATER-1LG	HEATER-PAD1-1LG	HEATER-PAD2-1LG	HEATER-PAD3-1LG
Small	SYRINGE-HEATER-5SP	HEATER-PAD1-5SP	HEATER-PAD2-5SP	HEATER-PAD3-5SP

8.2 RS-232 Network Cables

RS-232 Network Primary Cable

7 foot cable	Part #: CBL-PC-PUMP-7
25 foot cable	Part #: CBL-PC-PUMP-25

Cable to connect the first device of an RS-232 network to a standard PC's serial port with a DB-9 connector.

RS-232 Network Secondary Cable

7 foot cable	Part #: CBL-NET-7
25 foot cable	Part #: CBL-NET-25

Cable to connect additional devices, after the first, to an RS-232 network.

USB to RS-232 Converter Cable

USB to RS-232 cable
Part #: CBL-USB232

Attaches to the RS-232 Network Primary Cable to allow communication through a PC's USB port. Includes a CD with software drivers.

9. Specifications

Power requirements	120 VAC 60Hz, North American style plug
Power consumption	0.33 A (One heating pad)
Maximum temperature setting	185 C (365 F)
Selectable temperature units	C (Celsius) or F (Fahrenheit)

Heating pad: HEATER-PADx-1LG

Pad size (PAD1-1LG)	L 9 cm x W 7.5 cm (3.5" x 3.0")
Cord length	5.4 cm (21")

Heating pad: HEATER-PADx-5SP

Pad size (PAD1-5SP)	Heating area: L 50 cm x W 1.5 cm (20.0"x0.625") Overall length: L 740 mm x W 15 mm (29.13"x0.59")
Cord length	90 cm (36")
Controller case dimensions	L 4.625" x W 2.5" x H 1.5" (11.7475 cm x 6.35 cm x 3.81 cm)
RS-232 network protocol	Baud rate: 19,200 Data Frame: 8N1
RS-232 network address range	00 to 99 (100 devices maximum)